



**C. E. Niehoff & Co.**  
BRUSHLESS ALTERNATORS

**N1211, N1211-2, N1211-4, N1211-5 Alternators  
with N3106 Regulator (N1211-2)  
or N3116 Regulator (N1211-4)  
or N3121 Regulator (N1211-5)  
Installation Instructions**

Make alternator connections as shown on this page.

See page 2 for regulator connections.

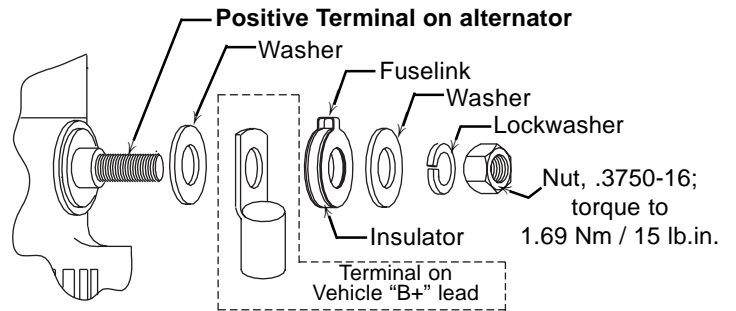

Figure 1a - Positive Terminal Connections

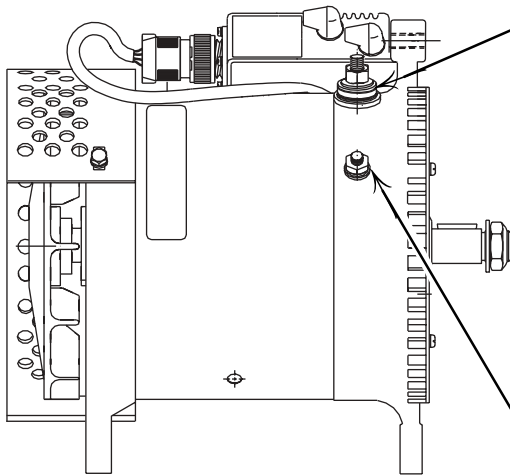

Figure 1 - Alternator (shown with regulator)

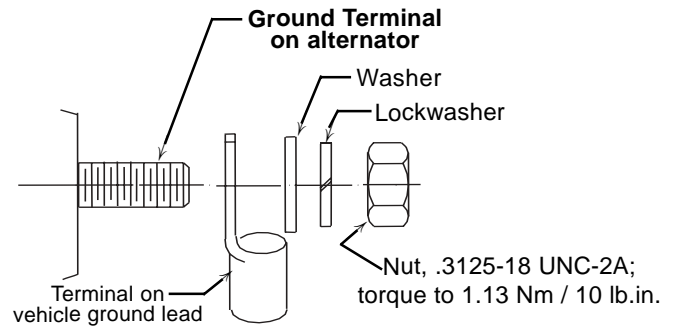

Figure 1b - Ground Terminal Connections

**Make regulator connections as shown on this page.**

**See page 1 for alternator connections.**

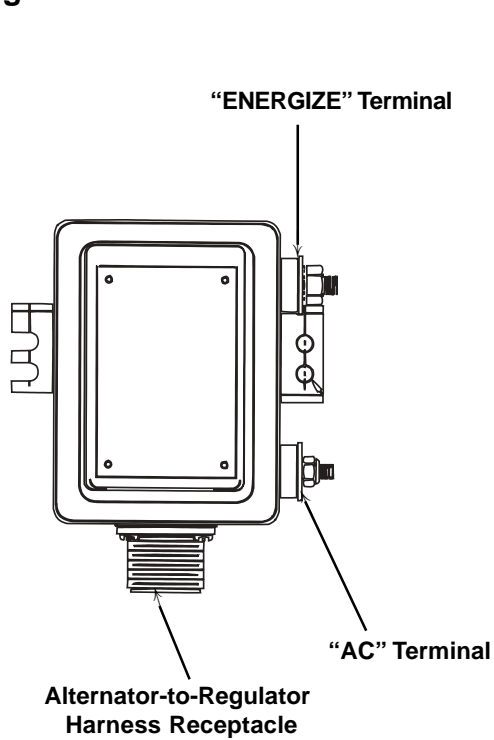

Figure 2 - N3116 Regulator Wiring Connections (also for N1211-4)

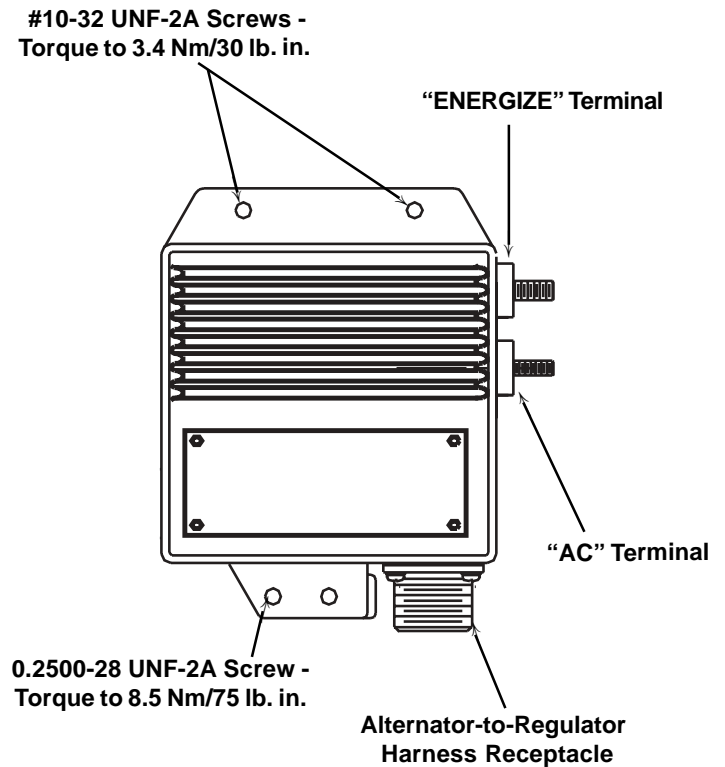

Figure 3 - N3121 Regulator Wiring Connections (also for N1211-5)

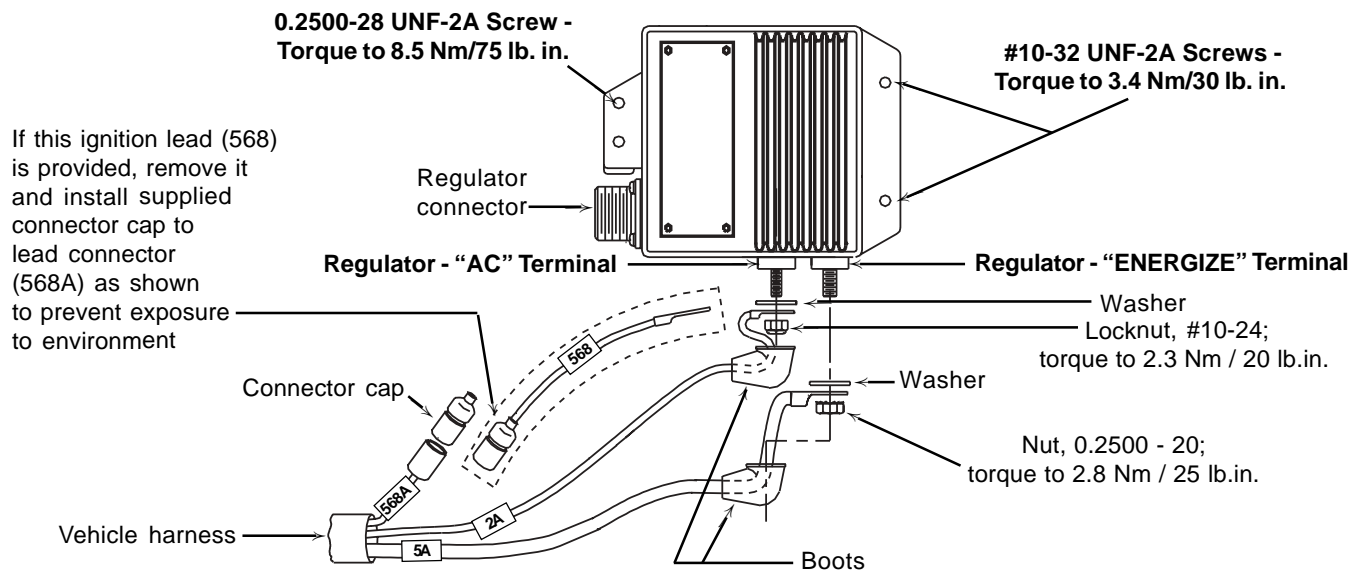

Figure 4 - N3106 Regulator Wiring Connections (also for N1211-2)