



**Regulator Changeout Instructions**

**CAUTION**

This symbol is used to indicate presence of hazards that can cause minor property damage.

**Removing regulator from N1224 alternator**

1. Remove battery cables from batteries and/or turn off master switch to disconnect vehicle batteries from vehicle.

**CAUTION**

If vehicle has dual voltage electrical system, be sure both 14 V and 28 V batteries are disconnected.

2. Gain access to regulator.
3. Mark cables and harness for ID and reassemble reference.
4. Remove cables and harness from regulator.
5. Remove and discard regulator mounting hardware.
6. Remove regulator.

**Re-installing regulator on N1224 alternator**

1. Remove battery cables from batteries and/or turn off master switch to disconnect vehicle batteries from vehicle.

**CAUTION**

If vehicle has dual voltage electrical system, be sure both 14 V and 28 V batteries are disconnected.

2. Set new regulator on alternator. Install and tighten new mounting hardware (in bag supplied with alternator) as shown in Figure 1.
3. Plug harness(es) into alternator as shown in Figure 1.
4. Attach and tighten cables to terminals as shown in Figure 1.
5. Reconnect batteries and/or turn on master switch, start engine, and verify alternator output/operation.

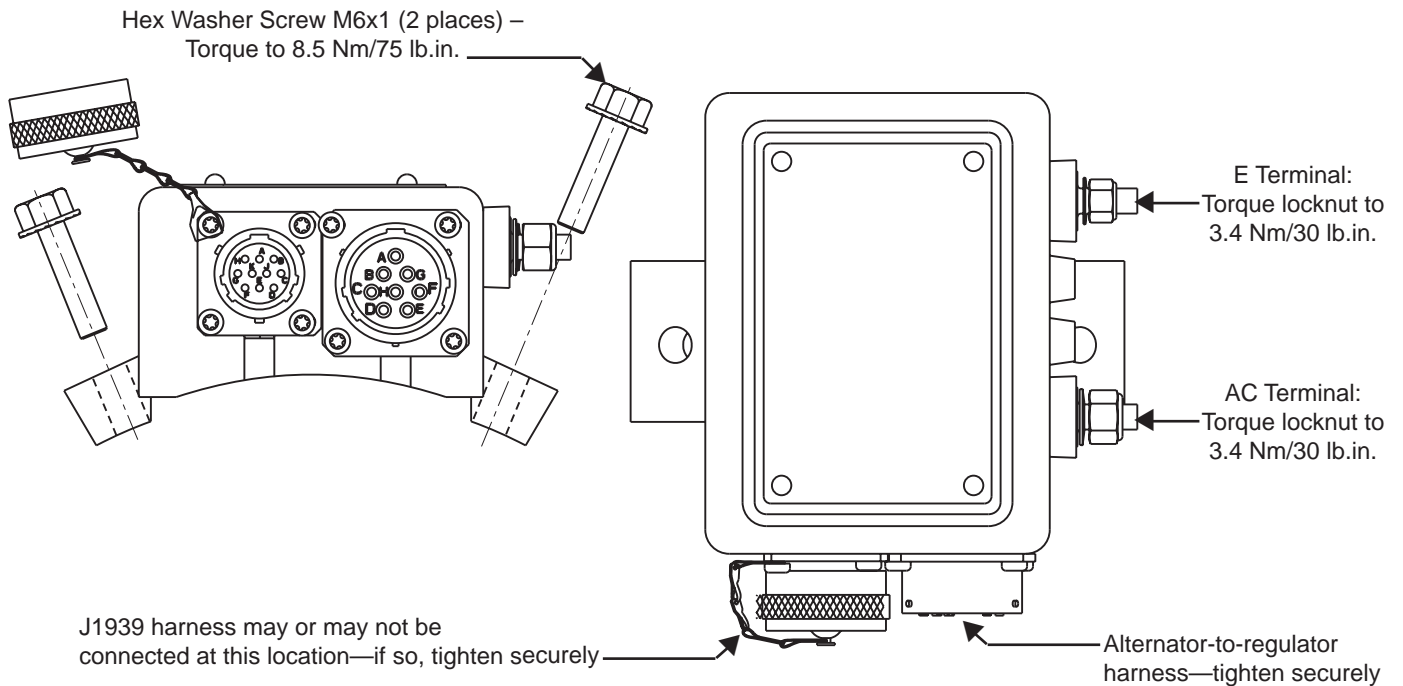

Figure 1 - Regulator/Harness Attachment