



TURN OFF BATTERY DISCONNECT SWITCH BEFORE PROCEEDING

1. From B+ terminal on alternator, remove and save hardware for reassembly.
2. Remove and save one screw from B+ output stud (see Figure 1). Clean off any residue from screw and screw hole.
3. See Figure 2. Connect leads of A9-321 assembly:
 - Red lead to B+ terminal as shown in stacking order. Torque terminal nut to 30 Nm/22 lb. ft.
 - Black lead to screw on B+ output stud (ref. step 2). Use a suitable adhesive such as Loctite® 222 on screw. Follow manufacturer's instructions. Torque to 4 Nm/35 lb. in.
4. Using cable ties, securely support the assembly to the vehicle B+ cable as shown in Figure 1.

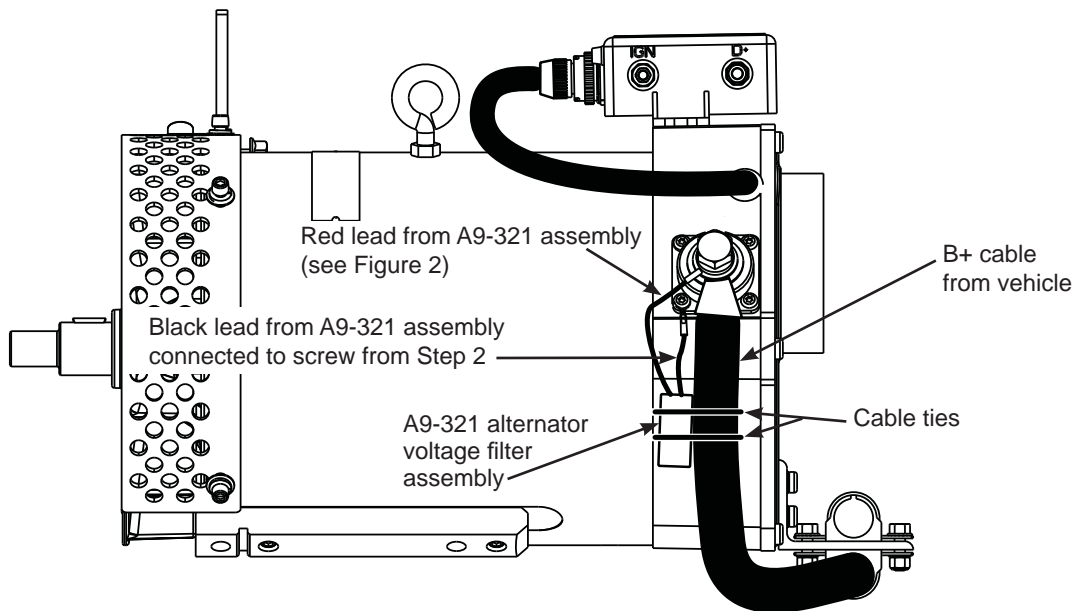

Figure 1 – C803D Alternator with A9-321 Assembly Installed

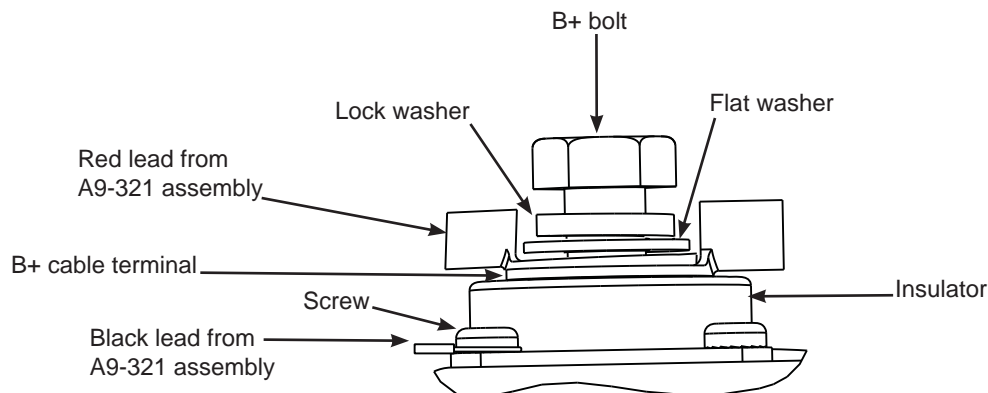

Figure 2 – A9-321 Alternator Voltage Filter Assembly Stacking Order